



STØTEK

A FURNACE FOR THE FUTURE:

**PRESENTING
THE STØTEK
DOSOTHERM[®] DTI**

Introducing the Dosotherm® DTI

The innovative STØTEK Dosotherm® DTI is a fully automatic dosing furnace made for quality aluminum handling. As the world's first immersion heater dosing furnace, the Dosotherm® DTI offers unprecedented dosing accuracy, metal quality and heating regulation.

STØTEK designed the revolutionary furnace by combining the veracity of dosing unit technology with highly-controllable immersion heating. The patented dosing system houses a unique ceramic unit that is pressurized for dosing metal, allowing the DTI Dosotherm® to produce high quality aluminum parts, such as structure parts and the like.

With its power and precision, the Dosotherm® DTI offers foundries an increase in dosing accuracy and metal quality, with a substantial decrease in metal loss and operational costs. Ensure your aluminum productions are fit for the future with the STØTEK Dosotherm® DTI.

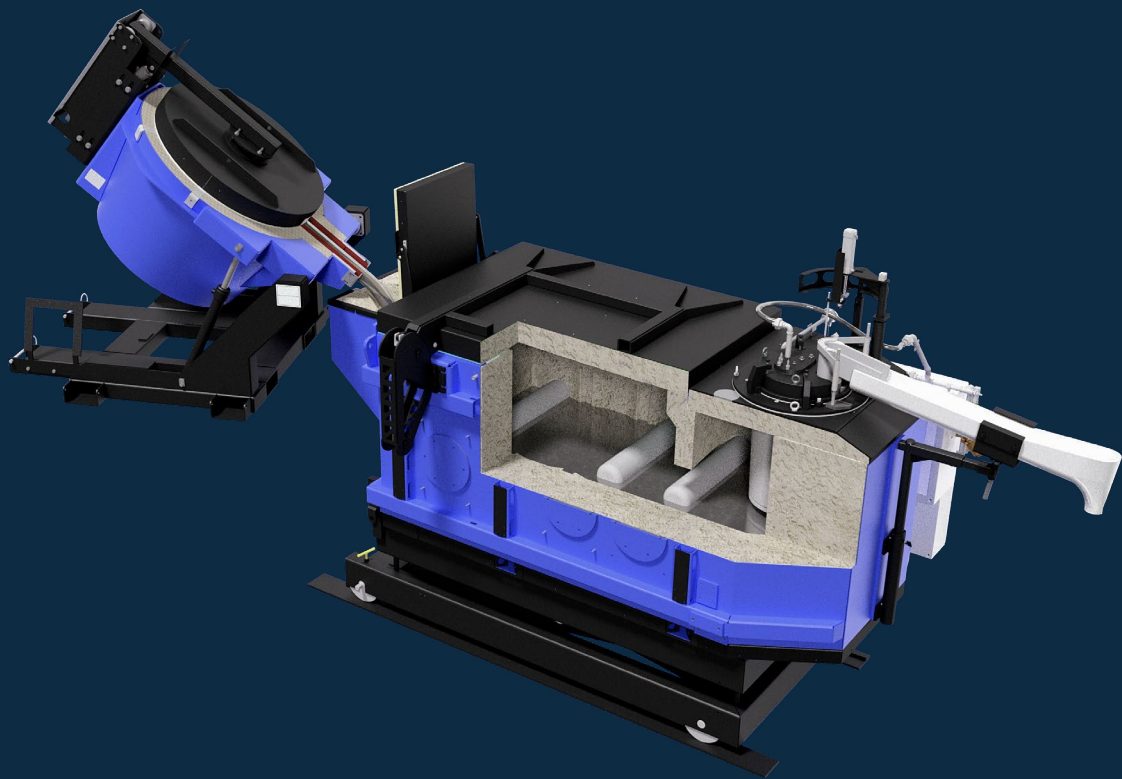

More information

Page 3: About Dosotherm® DTI

Page 4: Furnance Specifications

Page 4: Product Color & Contents

Page 5: Dosotherm® DTI Benefits

Page 5: About STØTEK

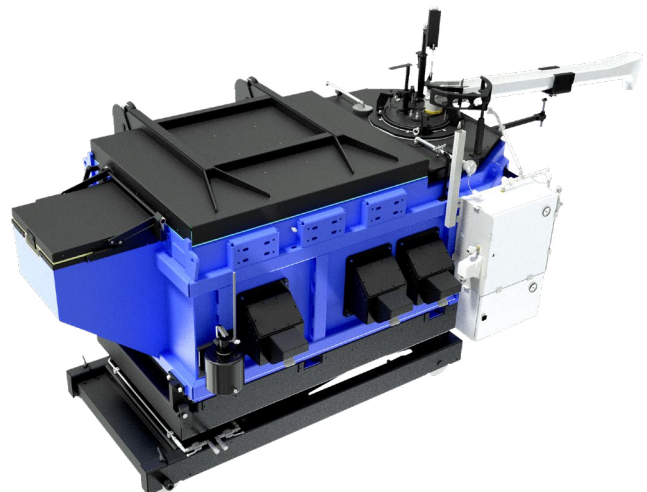

Dosotherm® DTI: The Future's Dosing Furnace

The inventive Dosotherm® DTI dosing furnace has been adopted by foundries all around the world, and with just one look at its features, it's easy to see why.

STØTEK's Dosotherm® DTI provides:

- Seamless charging and cleaning during aluminum production
- The ability to replace spare parts during the production process
- Secured and clean metal due to the no pressure being inside the furnace
- Quick and accurate dosing of metals
- Reduced charging height which creates homogenous, high-quality metal
- The option to utilize protective gas when dosing
- Pressurized unit technology to move aluminum easily
- An agile furnace that communicates with the pressure die-casting machine to choose appropriate recipes

When compared to other dosing furnaces, STØTEK's Dosotherm® DTI has been shown to save foundries considerable time, energy and money:

- EUR 7,500 – Average saved due to lowered energy costs
- EUR 2,500 – Average saved due to compress air costs
- 50% faster cycle time overall
- Up to 98% more productive cleaning during production

With its improvements to aluminum production flow, energy consumption, metal quality and dosing accuracy, the Dosotherm® DTI is the dosing furnace of the future.

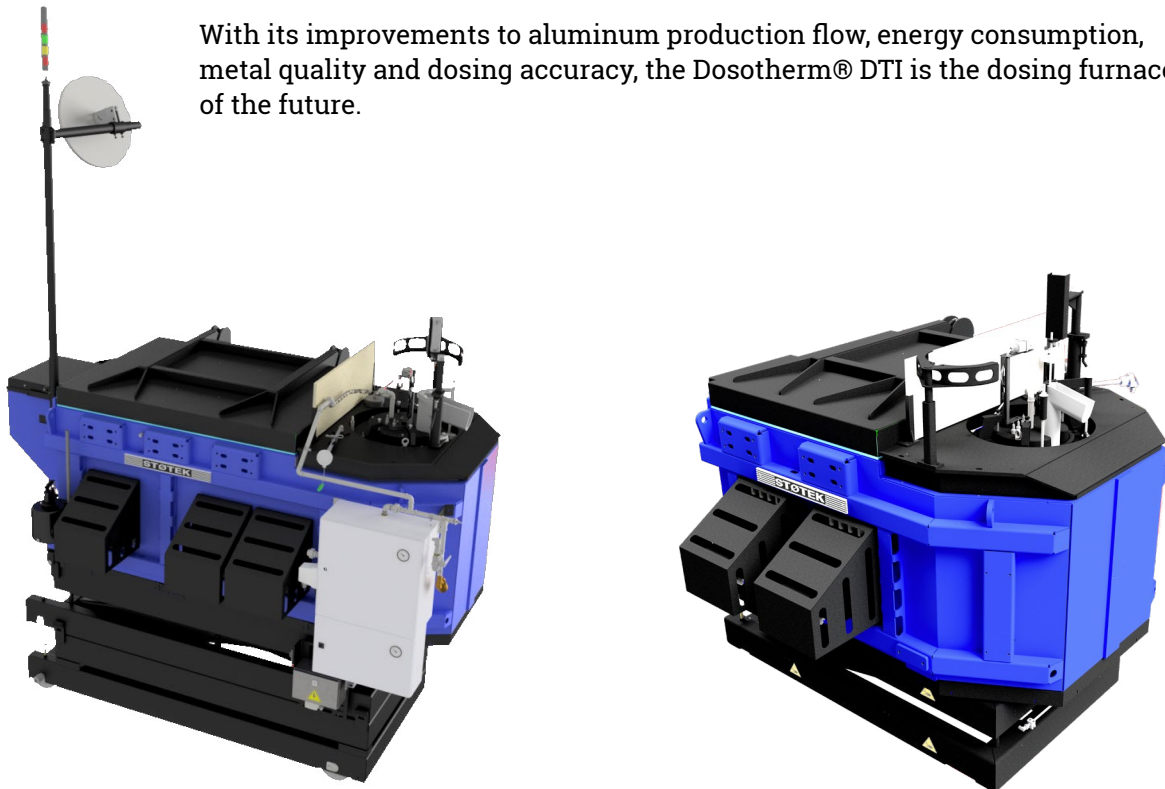

Furnace Specifications

STØTEK's Dosotherm® DTI has a range of available models that carry various capacities and power levels. These diverse models allow STØTEK to provide each of their clients with a customized dosing solution that best supports their specific needs.

STØTEK DOSOTHERM®	DTI1520	DTI2020	DTI 2520	DTI4020	DTI6020
Holding Capacity (Calculated at ρ 2,6kg)	1450 kg	2000 kg	2500 kg	4000 kg	6000 kg
Dosing weight	1,0-20,0 kg	5,0-65,0 kg	5,0 – 65,0 kg	5,0-90,0 kg	5,0-150 kg
Max. bath temperature	780°C	780°C	780°C	780°C	780°C
Power consumption (Calculated)	7 kWh	9 kWh	11 kWh	16 kWh	21 kWh
Power connection	21 kW	31,5 kW	45 kW	45 kW	75 kW
Delivery spout height with standard lifting table	1474 mm + 600 mm	1574 mm + 600 mm	1574 mm + 800 mm	1574 mm + 1150 mm	1767 mm + 1005 mm
Length	2750 mm	3076 mm	3296 mm	3372 mm	4520 mm
Width	1430 mm	1430 mm	1430 mm	1773 mm	2408 mm
Height	1895 mm	1995 mm	1995 mm	1995 mm	2593 mm
Heating elements	2 pcs.	3 pcs.	3 pcs.	3 pcs.	5 pcs.
Dosing accuracy	±1% by weight	±1% by weight	±1% by weight	±1% by weight	±1% by weight

Foundries can find the best DTI furnace for them, depending on the necessary aluminum capacity, power source, energy input and dosing weight, among other aspects.

Product Color & Contents

All dosing furnace models have a clean coloring of black, blue and grey and contain the following content pieces with each order:

- 1 - Standard holding and dosing furnace
- 1 - Dosing unit system and pneumatic panel
- 1 - Ceramic spout
- 1 - Dosing and heat control cabinet
- 1 - Adjustable, moveable lifting and tilting table
- 1 set- Hard copy instruction manual and signs in local language (Furnace is delivered with QR-code, where manual can be found online)

Dosotherm® DTI Benefits

Employing the world's first immersion heater dosing furnace has a wide range of advantages, both in production and overall industry resilience:

- High efficiency of production, resulting in up to 80% reduction in energy costs and ROI in less than 1 year
- Competitively low oxidation in production, resulting in up to 90% reduction in metal loss**
- Superb process and energy savings of more than 40%
- 40% CO2 reduction compared to industry average
- High metal control capabilities with DTI's no gas exchange used and low surface temperature
- Improved dosing accuracy of more than +/- 1 %
- Increased metal temperature accuracy of +/- 1-degree Celsius
- Superior heating element life
- Very high metal quality from filter under dosing unit
- Excellent lining life of average 10 years or more
- Extremely low air consumption for dosing
- Hydraulic height adjustment and back tilting
- Online access to the furnace management system
- Intelligent communication with die casting equipment
- Easy to clean and fill with majority of wear parts operationally replaceable
- Unparalleled, local customer service and support
- Optional degassing stone and gate baffles for filtration

* When compared to an open well furnace with ladle

** Nitrogen or argon supply are required

About STØTEK

Founded in 1987, STØTEK has grown to become one of the leading voices in the automotive foundry industry. Our range of innovative aluminum dosing technologies has made them a preferred partner for all businesses looking for quality, energy-efficient and customizable aluminum casting solutions.

STØTEK solutions are rooted in the foundation of potency, quality and accuracy, resulting in dosing unit technology that is revolutionary both in practice and production. With a mission to ensure effective processes for superior aluminum parts while providing strong, local customer support, STØTEK reserves their position as a company fit for the future of the dynamic automotive industry.